

embedded adventures

Device: MOD-1016

This document Version: 1.0

Matches module version: v2

Date: 9 December 2012

Description: Lightning and Storm Sensor



Contents

Introduction.....	3
Features.....	3
Hackability.....	3
Construction	3
Connections.....	3
Power	4
Pull up resistors	4
Tips and tricks	4
Warning	5
Schematic.....	6
PCB.....	6
Versions	7

Introduction

The MOD-1016 is an AS3935 based lightning and storm sensor. It comes pre-calibrated, meaning that you don't have to write complex frequency calculation code, you can simply program the correct calibration details and get cracking finding storms.

Features

The MOD-1016 features the AS3935 from AMS. It features an I2C interface, can operate down to 2.4V and up to 5.5V, and provides detection of storm fronts up to 40km away.

Hackability

The MOD-1016 is 100% hackable.

At Embedded Adventures, we believe you have the most fun when you have the most control over your hardware. For the MOD-1016 we provide a datasheet, and complete schematic. After that, it's all up to you. We'd love to hear about the projects you're using it for – send us information and photos to myproject@embeddedadventures.com

Construction

It's all pre-built! Just add female or male header pins, or solder directly to the board, and away you go.

Connections

The MOD-1016 has one connection ports.

VCC	Positive supply. 2.4V – 5.5V.
SDA	I2C serial data
SCL	I2C serial clock
IRQ	Interrupt request from AS3935
GND	Ground (Vss) connection.

Power

The MOD-1016 can be powered from 2.4V – 5.5V. It uses 8uA while in power down mode and 65uA when listening for lightning. When verifying lightning and calculating distances, the device consumes 350uA.

Pull up resistors

I2C requires the use of pull-up resistors. The board comes with the pull-up resistors enabled. If you are connecting to an existing I2C buss that already has pull-up resistors, or you are using internal pull-ups in your microcontroller, you can disable the pull-up resistors by unsoldering the resistors R1 and R3 (the 10K resistors on the right hand side of the board).

Tips and tricks

These are the steps you need to take to start using the MOD-1016. Your MOD-1016 comes pre-calibrated – meaning you don't need to worry about measuring frequencies and checking results.

- Wait a few milliseconds for the system to stabilise
- Set the tune capacitor to the value indicated on the packaging, by setting the TUNE_CAP bits of register 8
- Wait 2 milliseconds
- Calibrate RCO by:
 - Sending a calibrate RCO direct command (set memory location 0x3d to the value 0x96)
 - Set Register 0x08, bit 5 to 1
 - Wait 2 milliseconds
 - Set Register 0x08, bit 5 to 0

There are many parameters to set and play with, but most importantly make sure you set the AFE gain to indicate if you are using the sensor inside or outside.

The module will then pull IRQ high when something interesting has happened. Respond to this by waiting 2ms, then checking Register 0x03, bits 3-0. This will indicate:

- Noise detected, above the general background level. You can usually make this happen by putting the MOD-1016 near a laptop or mobile phone, and the minimum acceptable of noise can also be configured.
- Disturber detected. A pulse was detected that was classified as man-made.
- Lightning. The real deal! At this point, you can query the MOD-1016 to find out how far away the storm front is, and also a number that represents the amount of energy the lightning has.
- No value. Due to the timing algorithms, the MOD-1016 has decided that the storm is now a different distance away than previously reported.

In general, it cannot be stressed enough that while the MOD-1016 will certainly let you know about electromagnetic pulses and its best guess about lightning distance, in real life storms do not generally hang around all the time ready for testing this module. Also, rain clouds don't necessarily mean lightning! Be patient, use your microcontroller to record what happens over time and enjoy learning more about storm patterns in your geographical location.

Warning

The MOD-1016 contains world-class, award winning, super advanced technology from AMS. However, this device should NOT be used as the basis for evacuation or safety decisions in the case of storms, hurricanes, cyclones or other weather events.

Please rely on local authorities to tell you what to do.

Schematic

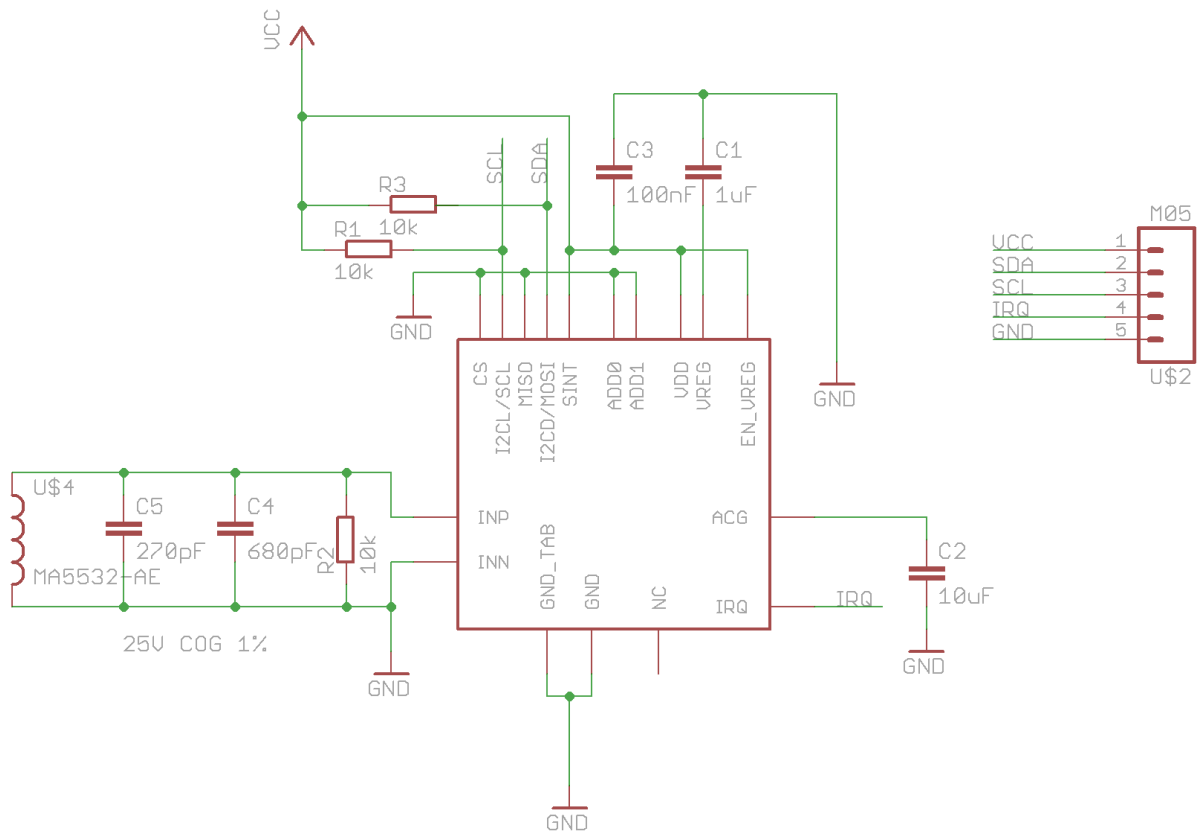

PCB

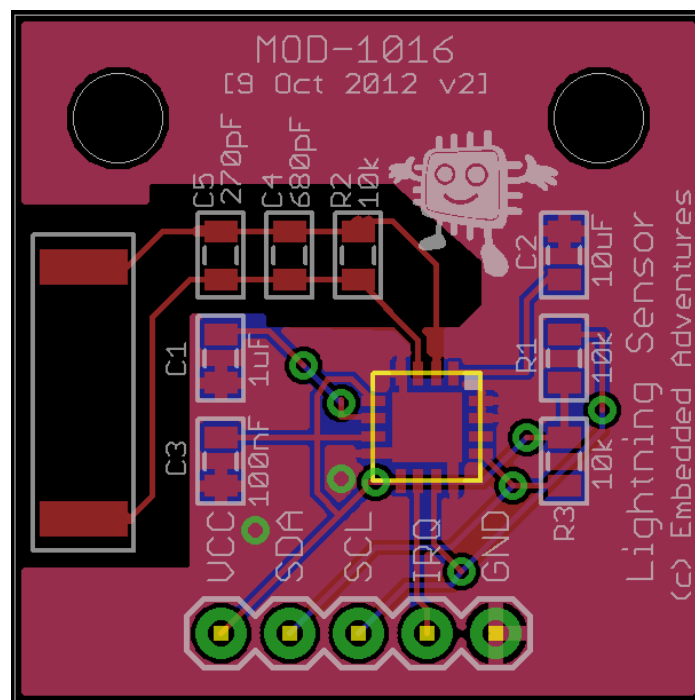

Versions

Doc Version	HW Version	Date	Comments
1.0	2	9 Dec 2012	Initial Version for board v2